PLEASE READ PRIOR TO INSTALLING THIS FAN

The WhisperGreen™ line of ventilation fans employs state of the art technology providing a number of unique features that lead to improved in-door air quality. These features need to be fully understood prior to installation to fully realize the benefits the fans offer.

Spot and Continuous Ventilation: These fans are designed to run continuously ensuring a healthy environment at low CFM levels 24 hours a day. By utilizing **CustomVent™ Variable Speed Control** the fans are built to run continuously at a pre-set lower level (30 – 70 CFM). The setting is dependent on the size of the room and the individual wishes of the homeowner. ***It is crucial that the installer pre-set the lower setting during the installation. Please refer to the chart below and page 5 of the installation instructions.***

**CustomVent™ Variable Speed Control (Lower Setting)
ASHRAE 62.2-2003**

(sq. feet)	Two Bedrooms	Three Bedrooms	Four Bedrooms	Five Bedrooms
< 1, 000	33	40	48	55
1,500	38	45	53	60
2,000	43	50	58	65
2,500	48	55	63	70
3,000	53	60	68	-

These fans are also built to take care of the homeowner's spot ventilation needs when the room is occupied. These models kick-up to a maximum level of 80 CFM either when the switch is turned on (FV-08VKS1) or activated by the **SmartAction™ Motion Sensor** (available with FV-08VKM1 only).







A High/Low Delay Timer, located inside the fan unit, is utilized to return the fan back to the pre-set continuous ventilation mode. ***The installer needs to consult with the homeowner for the desired setting on the timer (30 seconds – 60 minutes) and make the adjustments during the installation.***

Optimum Ventilation Performance: Generally duct length, elbows and other factors increase static pressure hindering the performance of most ventilation fans. These fans utilize **SmartFlow™** microchip technology that monitors the static pressure in the system and speeds up or slows down the rpm of the fan depending on the amount of resistance. This allows the fan to perform as rated, whether facing 0.1, 0.2 or even 0.25 inches water gauge. The bottom line is that it makes for easier installation. The installer no longer has to worry about compromising the fan's performance.

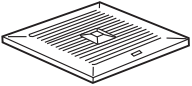
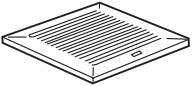
Outstanding Energy Savings: These fans are the very first to be build using DC motor technology. The new DC motor is 30% - 70% more energy efficient than the minimum ENERGY STAR requirements.

SUPPLIED ACCESSORIES

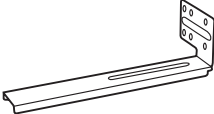
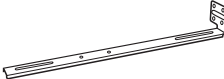
FV-08VKM1
FV-08VKS1

Part name	Appearance	Quantity
Grille	 FV-08VKM1	1
	 FV-08VKS1	1
Long screw (M4X30)		8
Thumb screw		1
Screw I (M4X8)		2
Screw II (M4X10)		2
Suspension bracket I		1
Suspension bracket II		1
Suspension bracket III		1

DESCRIPTION

These Panasonic ceiling mount ventilating fan models use a sirocco fan with dolphin-shaped blades driven by brushless direct current motor powered by an integral transformer. The motor is designed to have long operating life, high dynamic response, higher speed ranges with saving energy. Double orifice technology is used to reduce noise. The grille covering the main body is a spring-loaded, quickremove type. A damper for preventing counterflow is provided. The double orifice technology and the sirocco fan are patented.

These Panasonic ceiling mount ventilating fan (FV-08VKM1) is equipped with motion sensor that run automatically when motion is detected. It is user-adjustable to operate 0.5~60 minutes after motion is no longer detected.

DIMENSIONS

FV-08VKM1

Unit: inches(mm)

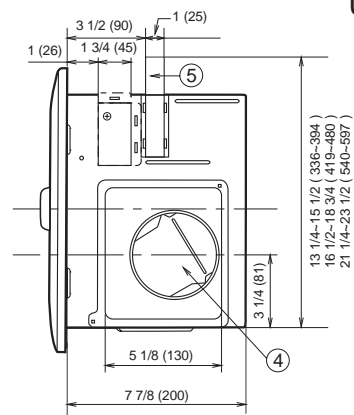
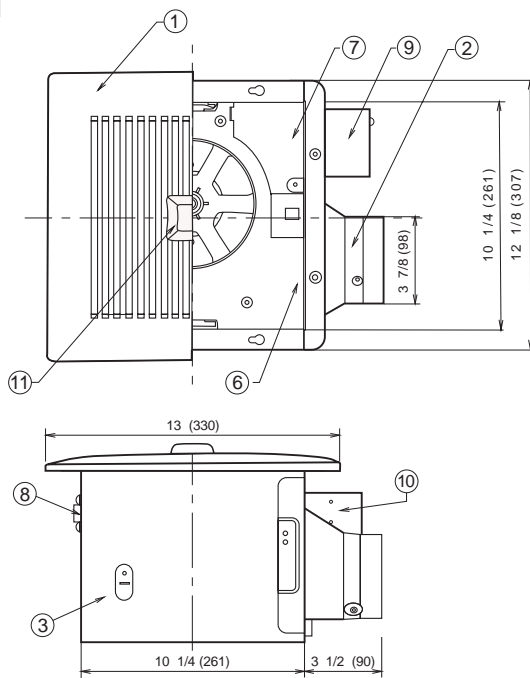

FV-08VKS1

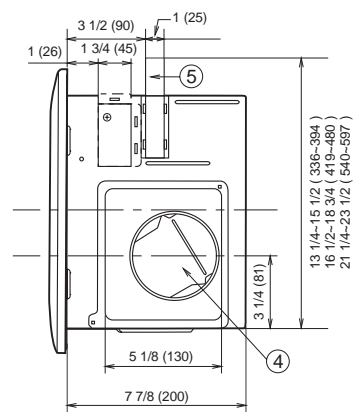
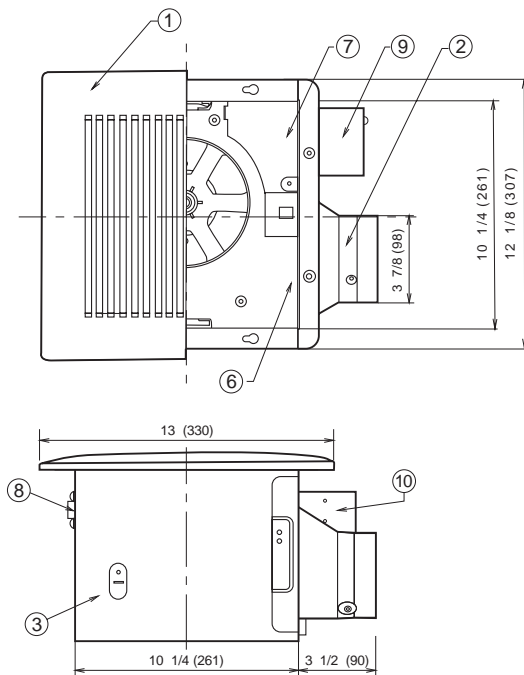

No.	Part name	No.	Part name
1	Grille	7	Orifice cover
2	Adaptor	8	Bracket cover
3	Fan body	9	Junction box cover
4	Damper	10	Junction box
5	Suspension bracket	11	Sensor unit
6	Orifice		

(For 16 inches on center joists, only use suspension bracket I, for 19.2 inches on center joists, only use suspension bracket III, If more than 19.2 inches on center, use suspension bracket II & III.)

WIRING DIAGRAM

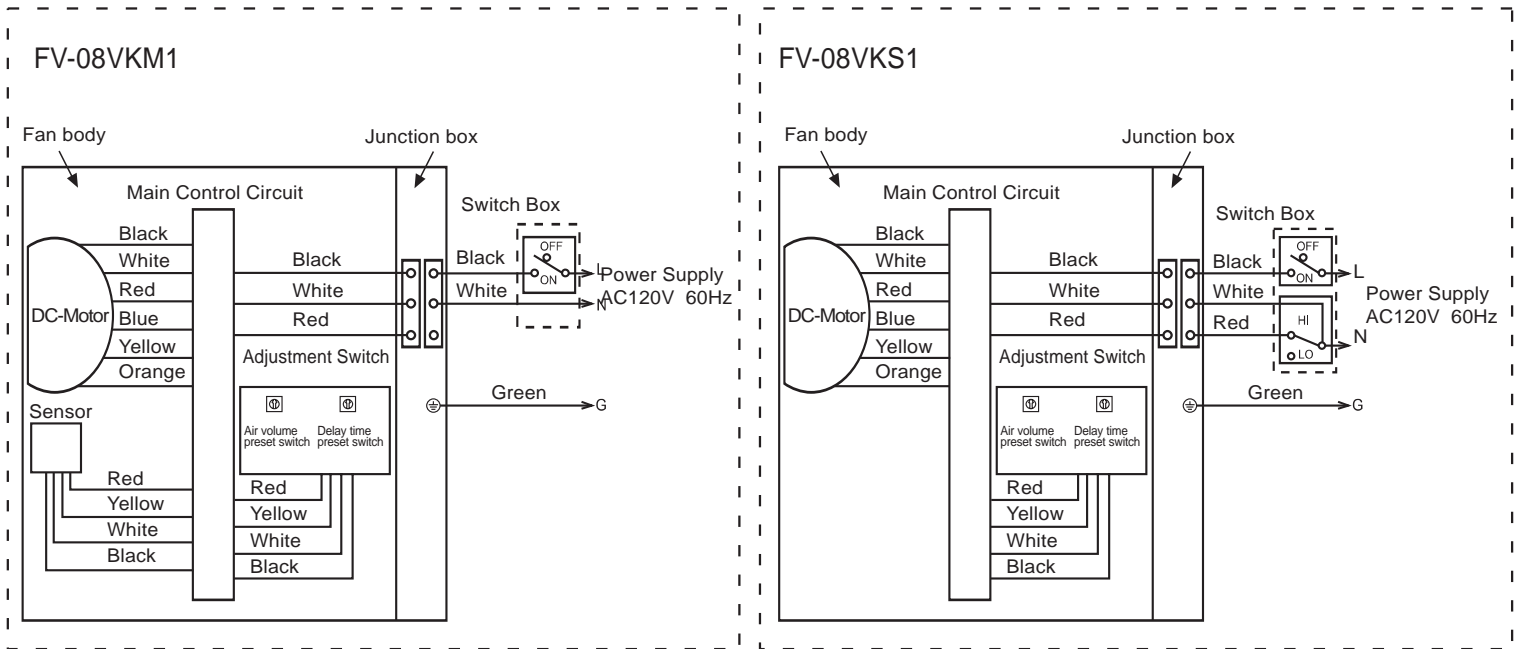

SWITCH INDICATION

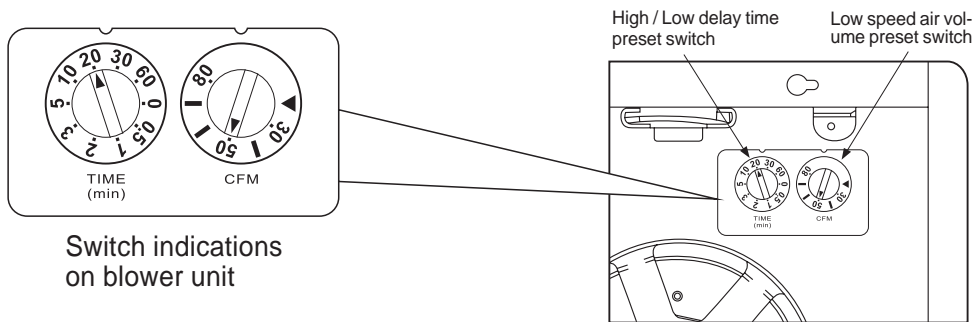

Low speed air-volume preset switch positions

Air Volume [CFM]	▶	30	40	50	60	70	80
------------------	---	----	----	----	----	----	----

Factory setting : 50 CFM

Position "▶" : Use for factory test only.

High/Low delay time preset switch positions

Delay Time [min]	0	0.5	1	2	3	5	10	20	30	60
------------------	---	-----	---	---	---	---	----	----	----	----

Factory setting : 20 minutes

Position "0" : Use for factory test only.

OPERATION

■ Detectable range

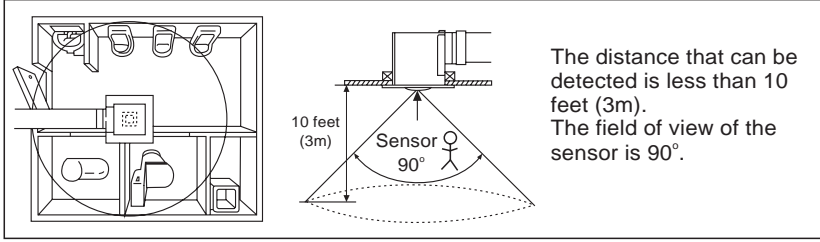

■ Motion sensor

- The low speed is determined by air volume preset switch.
- The delay time is determined by High/Low delay time preset switch.
- Running maintains at high speed for adjustable duration 0.5 to 60 min. after motion is no longer detected.

FV-08VKM1	Human active		
	Fan active	At low speed	When motion is detected, fan runs at the high speed.

FV-08VKS1	Human active		
	Fan active	At low speed	When manual wall switch is touched, fan runs at high speed.

SPECIFICATIONS

■ Specifications

Model No.	Air direction	V	Hz	Duct diameter (inches)	Noise (sone)	Power consumption (W)	Speed (rpm)	Air deliver at 0.1" WG(cfm)	Weight kg (lb.)
FV-08VKM1 FV-08VKS1	Exhaust	120	60	4	0.3	12.5	750	80	6.5 (14.2)

HVI Certified Performance based on HVI Procedures 915, 916, and 920.

■ Reference specifications

Model No.	Air direction	V	Hz	Duct diameter (inches)	Noise (sone)	Power consumption (W)	Speed (rpm)	Air deliver at 0.1" WG(cfm)	Weight kg (lb.)
FV-08VKM1 FV-08VKS1	Exhaust	120	60	4	< 0.3	10.4	720	70	6.5 (14.2)
					< 0.3	8.5	695	60	
					< 0.3	7.4	680	50	
					< 0.3	5.4	630	40	
					< 0.3	4.0	580	30	

Reference performance based on HVI Procedures 915, 916, and 920.

UNPACKING

Unpack and carefully remove unit from carton.
Refer to the Supplied Accessories list to verify that all parts are present.

GENERAL SAFETY INFORMATION

1. Do not install this ventilating fan where air temperature may exceed 40°C (104°F).
2. Make sure that the electric service supply voltage is 120V, 60 Hz.
3. Follow all local electrical and safety codes, as well as the National Electrical Code (NEC) and the Occupation Safety and Health Act (OSHA).
4. Always disconnect the power source before working on or near the fan, motor or junction box.
5. Protect the power cord from sharp edges, oil, grease, hot surfaces, chemicals or other objects.
6. Do not kink the power cord.
7. Do not install the unit where ducts are configured as shown in Fig. A.
8. Provide suction parts with proper ventilation.
9. This unit is UL listed for use over a bathtub or shower when installed in a GFCI protected branch circuit.
10. These fans are intended for residential usage only.
11. For use in non fire rated installations only.
12. For use in one-and two-family dwellings only.

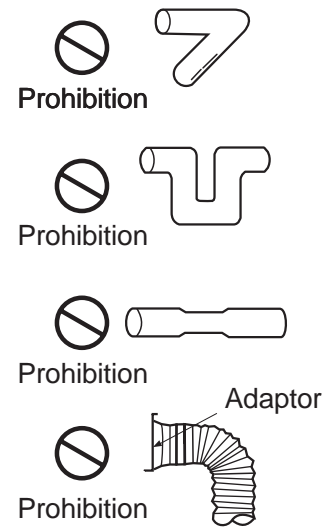

Fig. A

CAUTION:

1. For general ventilating use only. Do not use to exhaust hazardous or explosive materials and vapors.
2. Not for use in cooking area. (Fig .B)
3. This product must be properly grounded.

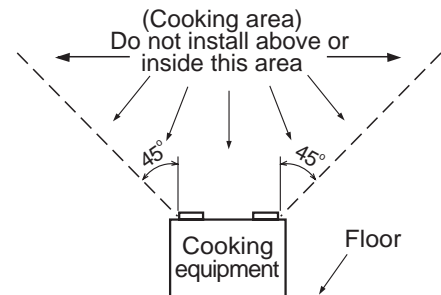

Fig. B

WARNING:

To reduce the risk of fire, electric shock or injury to persons, observe the following;

- A. Use this unit only in the manner intended by the manufacturer. If you have any questions, contact the manufacturer.
- B. Installation work and electrical wiring must be done by qualified person(s) in accordance with all applicable codes and standards, including fire-rated construction.
- C. Sufficient air is needed for proper combustion and exhausting of gases through the flue (chimney) of fuel burning equipment to prevent back drafting. Follow the heating equipment manufacturer's guideline and safety standards such as those published by the National Fire Protection Association (NFPA), and the American Society for Heating Refrigeration and Air Conditioning Engineers (ASHRAE) and the local code authorities.
- D. When cutting or drilling into wall or ceiling, do not damage electrical wiring and other hidden utilities.
- E. Ducted fans must always be vented to the outdoors.
- F. These models are UL listed for tub and shower enclosures.
- G. Do not use this unit with any solid-state control device. Solid state controls may cause harmonic distortion which can cause motor humming noise.
- H. Before servicing or cleaning unit, switch power off at service panel and lock the service disconnecting means to prevent power from being switched on accidentally. When the service disconnecting means cannot be locked, securely fasten a prominent warning device, such as a tag, to the service panel.
- I. NEVER place a switch where it can be reached from a tub or shower.
- J. Not to be installed in a ceiling thermally insulated to a value greater than R40.

INSTALLATION I (JOIST MOUNTING-I)

1. Before installation, open the orifice cover. Secure the fan body to adaptor by using thumb screw. (Fig.1)

Press and hold the claw of orifice cover to open the orifice cover.

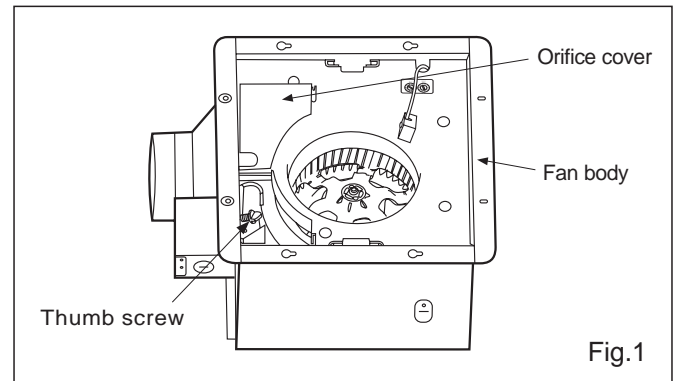
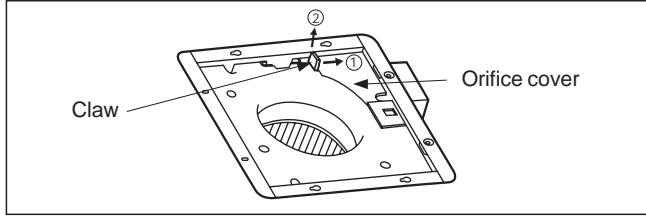

Fig.1

IMPORTANT:
Remove the tape from damper and adaptor before installation. As shown below:

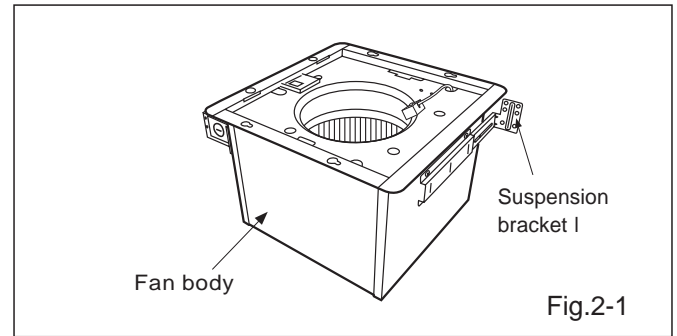
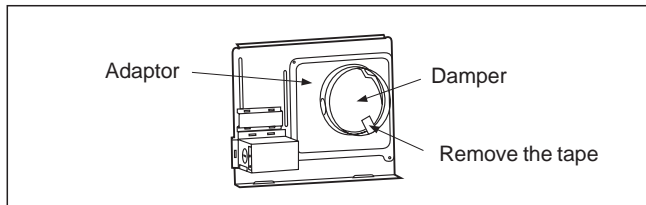

Fig.2-1

2. Insert the suspension bracket into the fan body and adaptor. (select the suspension bracket as shown below)

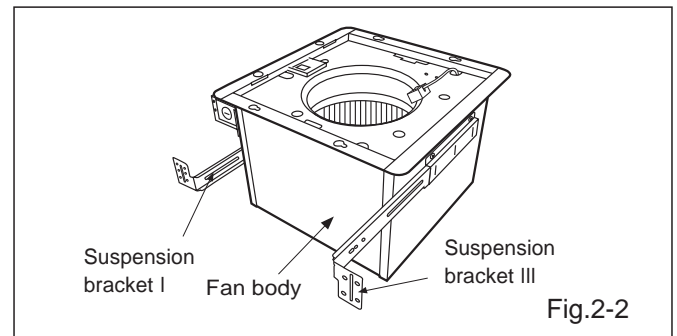
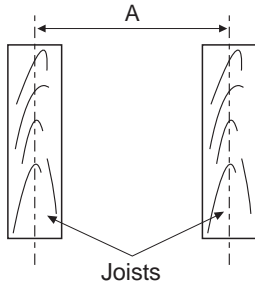

Fig.2-2

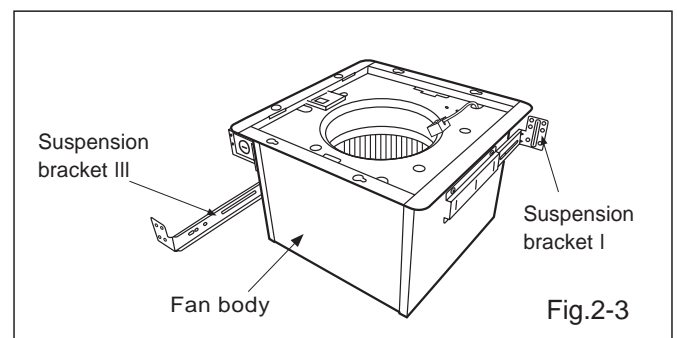

Fig.2-3

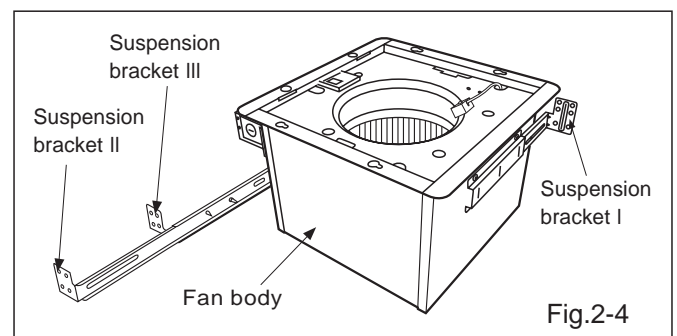
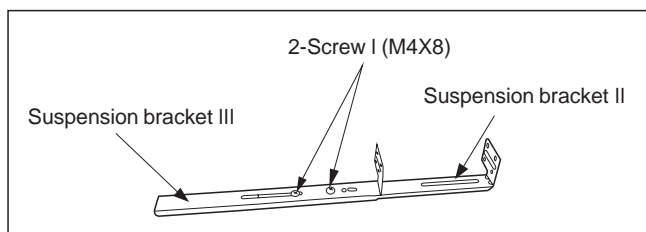

Fig.2-4

Spacing A on center Joists	Insert Suspension bracket
12 inches	Refer to Fig. 2-1
16 inches	Refer to Fig. 2-2
19.2 inches vertical joists	Refer to Fig. 2-3
24 inches	Refer to Fig. 2-4

If spacing A on center joists is 24 inches, connect suspension bracket II and III (C4 mark to C4 mark) as shown below :



INSTALLATION I (JOIST MOUNTING-I) CONTINUED

3. Install the suspension bracket and the flange of fan body to joists by using long screws (M4X30) (If spacing A between joists is 12 inches, install the flange of fan body according to Fig.3-2, others according to Fig.3-1 to install the product)

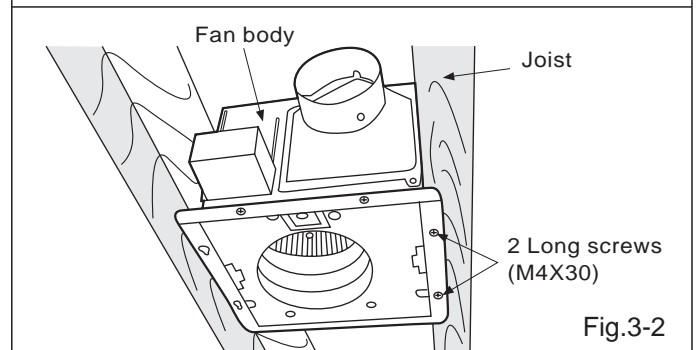
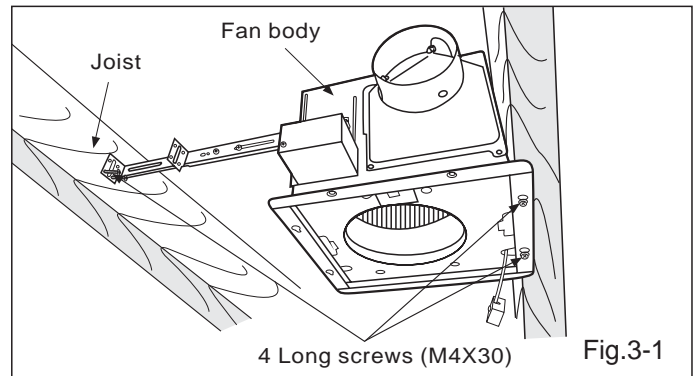

4. Install the suspension bracket to joists by using long screws (M4X30) and secure it to the fan body by using screw II (M4X10) (Fig.4)

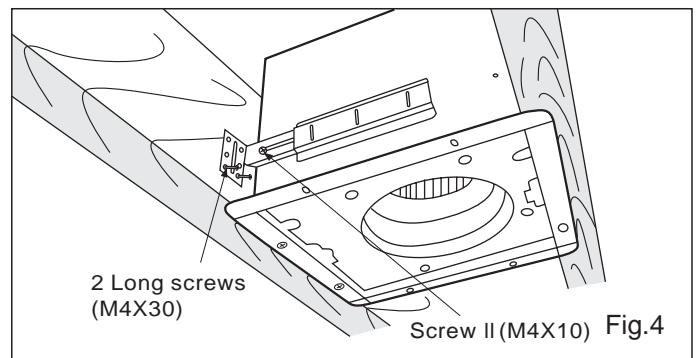

5. Remove junction box cover and secure conduit or stress relief to junction box knock-out hole. (Fig.5)

6. Refer to wiring diagram of page 5.
Using wire nuts, connect house power wires to ventilating fan wires:
black to black; white to white; green to green;
red to red. Replace the junction box cover.

CAUTION:
Mount junction box cover carefully so that lead wires are not pinched.

7. Install a circular duct and secure it with duct tape or clamps.

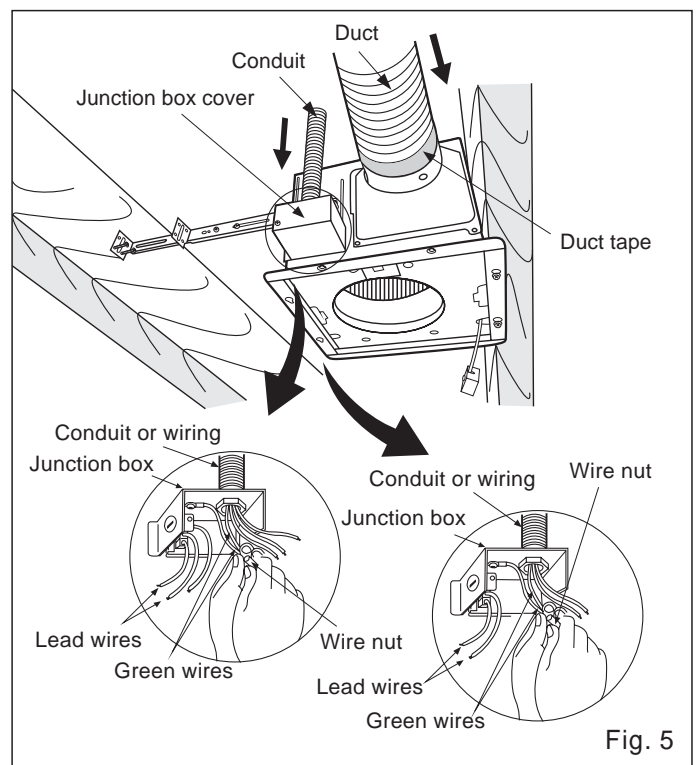

INSTALLATION I (JOIST MOUNTING-I) CONTINUED

8. Finish ceiling work. Ceiling hole should be aligned with the edge of the flange. Insert the sensor unit into slot of the grille (FV-08VKM1). (Fig.6)

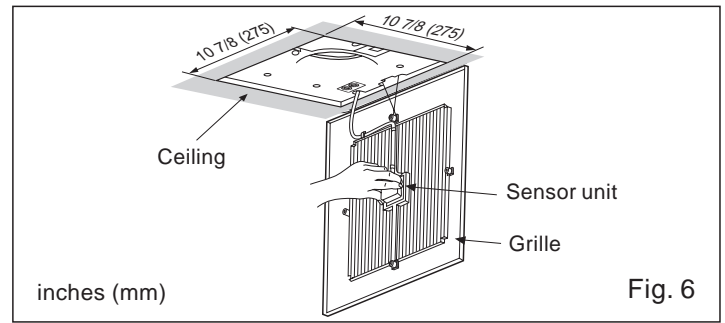

9. Adjust high/low delay time preset switch and low speed air volume preset switch. Refer to switch indication of page 5. (Fig.7)

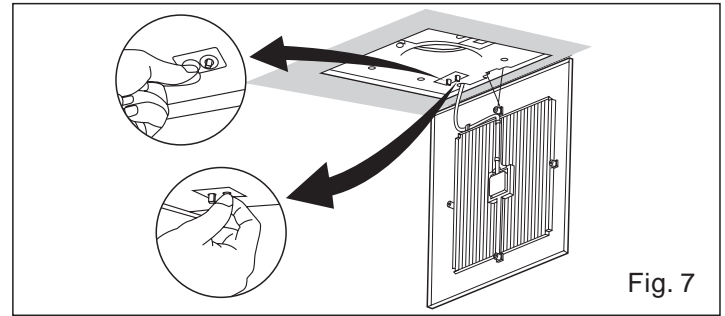

10. Insert mounting springs into slots as shown and mount grille to fan body. (Fig.8)

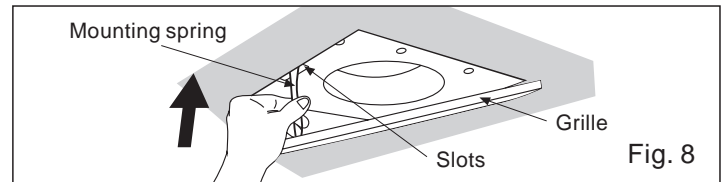

INSTALLATION II (JOIST MOUNTING-II)

1. Open the orifice cover, disconnect plug connector from receptacle and remove adaptor from fan body before starting installation.

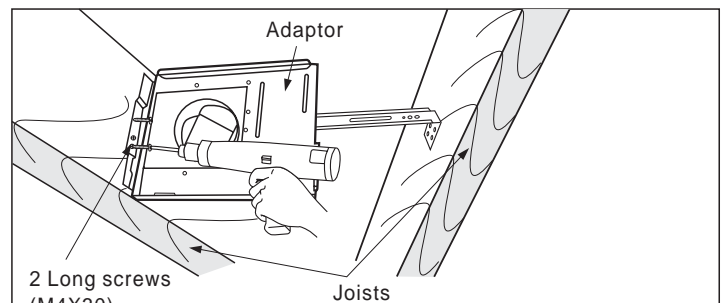

2. Insert the suspension bracket into the adaptor and secure it to joists by using long screws (M4X30) (Fig.9) Keep the distance B (7/8 inch, 21.6mm) for the thickness of ceiling board.

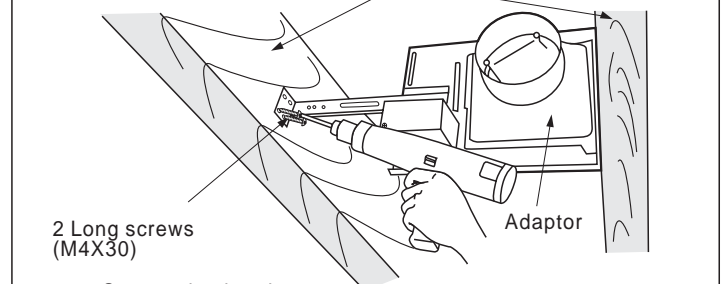

If spacing A between joists is 21 1/4 to 23 1/2 inches (540 to 597mm), connect suspension bracket II and III (C4 mark to C4 mark) according to page 8. Select the suspension bracket according to spacing A as shown below.

Spacing A between Joists inches (mm)	13 1/4~15 1/2 (336~394)	16 1/2~18 3/4 (419~480)	21 1/4~23 1/2 (540~597)
suspension bracket	suspension bracket I	suspension bracket III	suspension bracket II & III

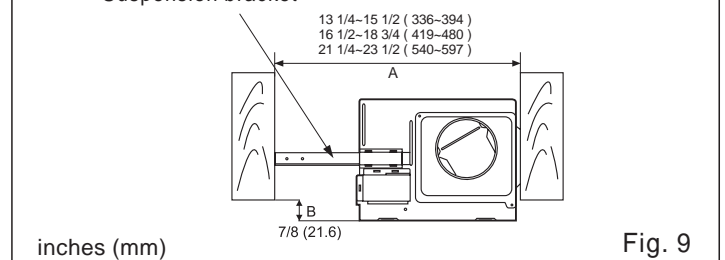

INSTALLATION II (JOIST MOUNTING-II) CONTINUED

3. Follow step 5 to 7 of the installation I (page 9) to complete the duct work and wiring.
4. Insert the suspension bracket into fan body (referring to step 2 of installation I, page 8)
5. Insert the fan body into joists. (Fig.10)

IMPORTANT:

Make sure that adaptor claws are properly inserted into body slots.

6. Open the orifice cover, secure the fan body to adaptor by using thumb screw. (Fig.11)
7. Plug connector to receptacle. (Fig.12)

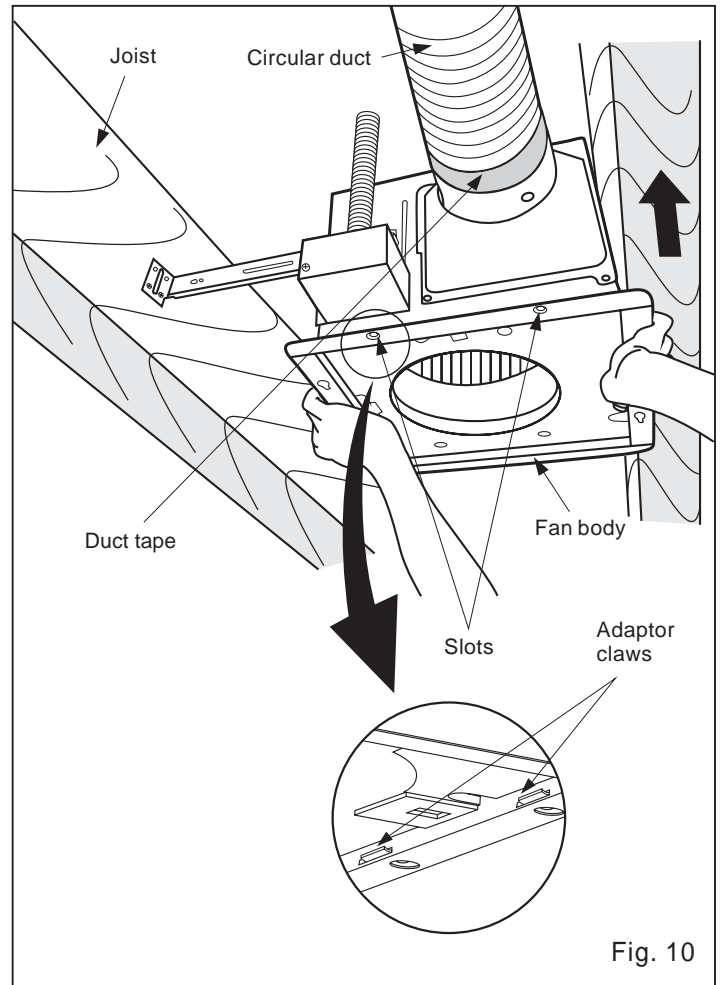

Fig. 10

When mounting body and blower separately

1. Loosen 3 screws (but do not remove them from blower). (Fig.13-1)
2. Remove blower section. (Fig.13-2)

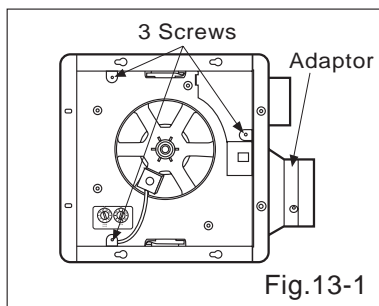

Fig.13-1

3. Remove adaptor from fan body and secure it to joists as in Fig.9 of page 10.

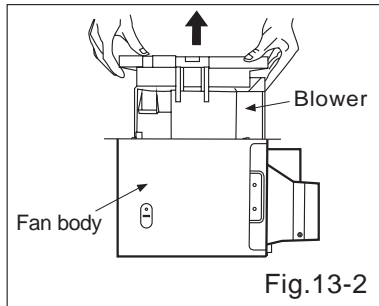

Fig.13-2

4. Insert fan body (without blower section) into joists. (Fig.10)

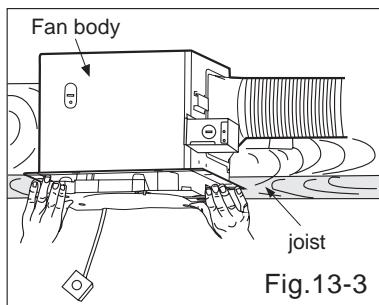

Fig.13-3

5. Secure the adaptor and fan body by using thumb screw. (Fig.11)

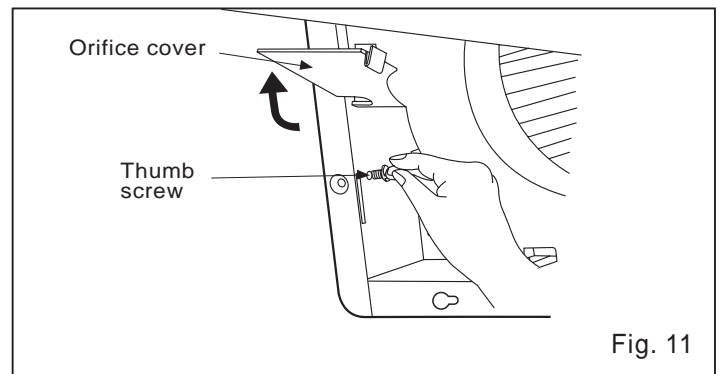

Fig. 11

6. Secure the fan body to joists by using long screw(M4X30) (Fig.14)

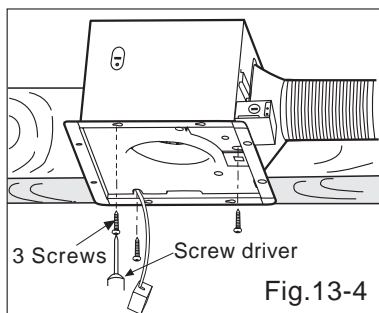

Fig.13-4

7. Insert the blower into the fan body. (Fig.13-3)
8. Secure the blower. (Fig.13-4) and plug connector to receptacle (Fig.12)

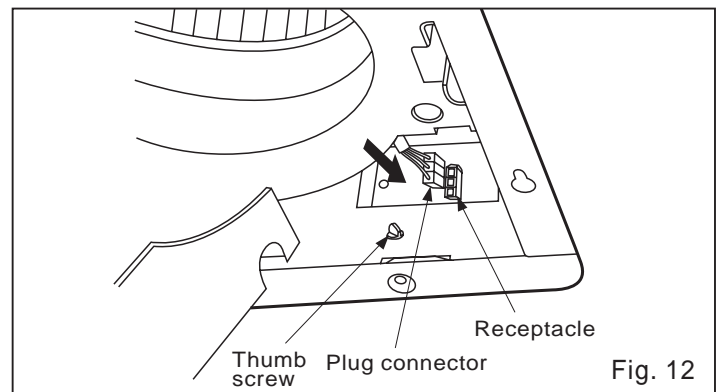
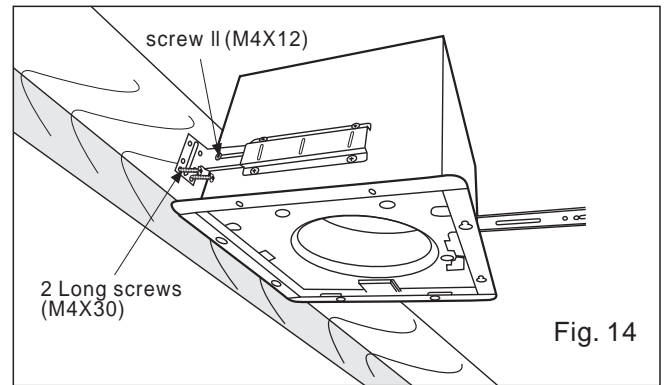

Fig. 12

INSTALLATION II (JOIST MOUNTING-II) CONTINUED

8. Secure the suspension bracket to joists by using long screws(M4X30) and secure it to fan body by using screw II (M4X10) in vertical direction (Fig.14)
9. Follow step 8 to 10 of Installation I (page 10) to complete the installation work.



INSTALLATION III (I - JOIST MOUNTING)

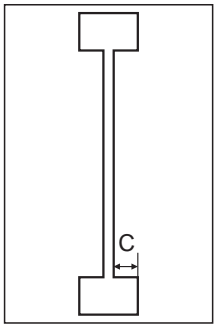

4 kinds of I-joist inches (mm)	
C1	9/16 (14.3)
C2	11/16 (17.5)
C3	31/32 (24.6)
C4	1 17/32 (38.9)

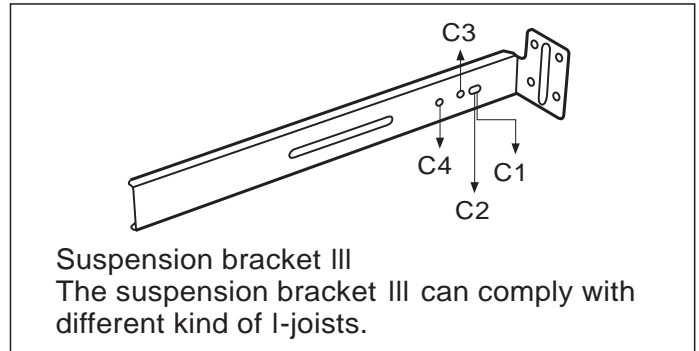

1. Before installation, open the orifice cover. Secure the fan body to adaptor by using thumb screw. (Fig.1 of page 8)
2. Connect the suspension bracket III to fan body. (Fig.15) (Select the hole by checking I-joist size fix the screw to the frame hole.)
3. Connect the fan body to the I-joist. (Fig.16)
4. Follow step 5 to 10 of installation I (page 9, page 10) to complete the installation work.

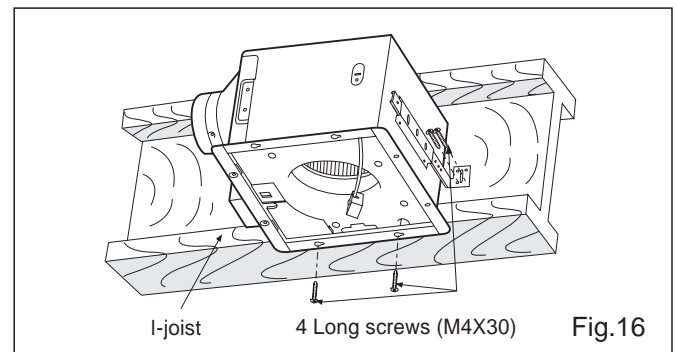
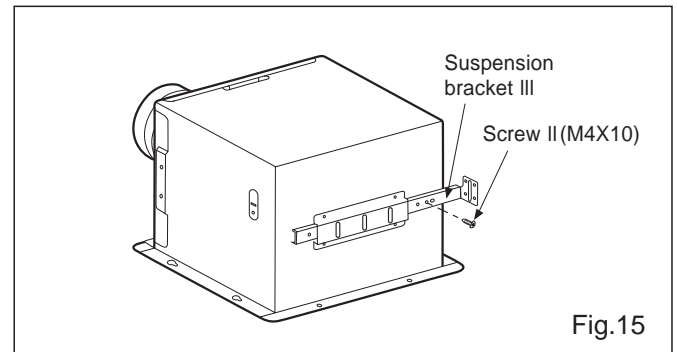

INSTALLATION IV (BETWEEN JOIST MOUNTING)

1. Before installation, open the orifice cover. Secure the fan body to adaptor by using thumb screw. (Fig.1 of page 8)
2. Insert the suspension bracket into the bracket cover of adaptor side and the back of the fan body. (Fig.17) (select the suspension bracket according to spacing A as show below)

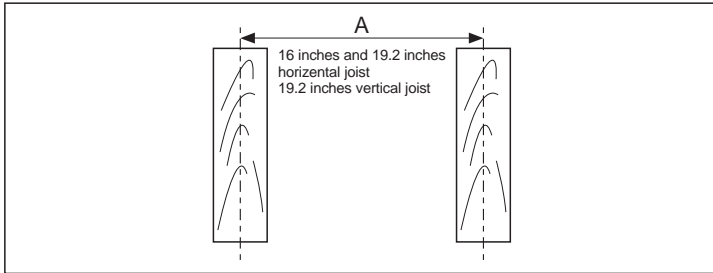

3. Insert the fan body between joists. Make sure the fan body is level and square (perpendicular) with the joists. (Fig.18) Keep the distance B (7/8 inch, 21.6mm) for the thickness of ceiling board.

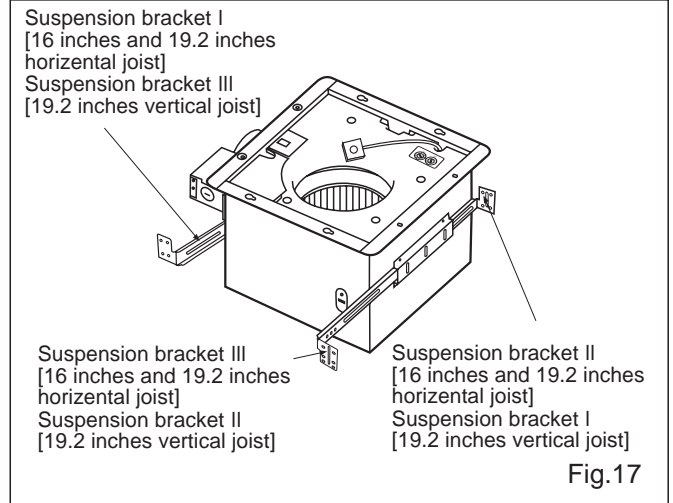

Fig.17

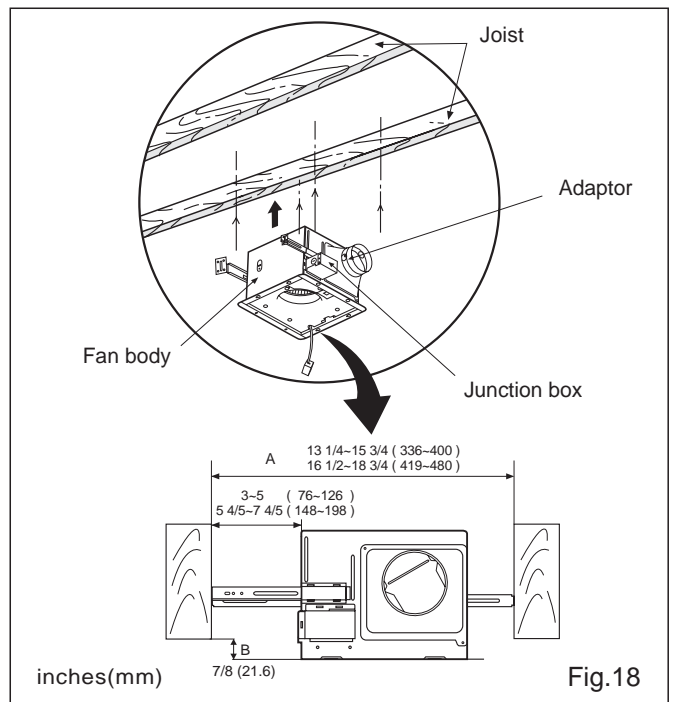

Fig.18

4. Secure the suspension bracket to joists by using long screws (M4X30) (Fig.19, Fig. 20 of page 13)

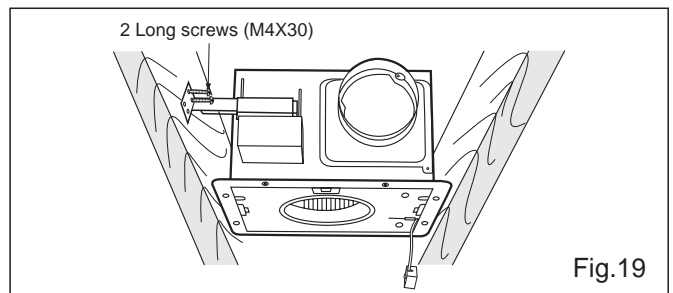

Fig.19

5. Secure the suspension bracket to the fan body by using screw II (M4X10) (Fig. 20)

6. Follow step 5 to 10 of installation I (page 9, page 10) to complete the installation work.

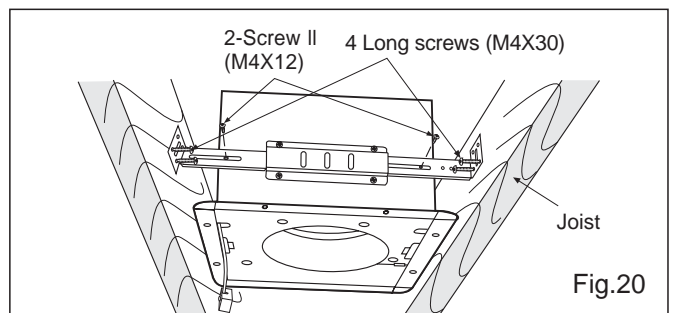
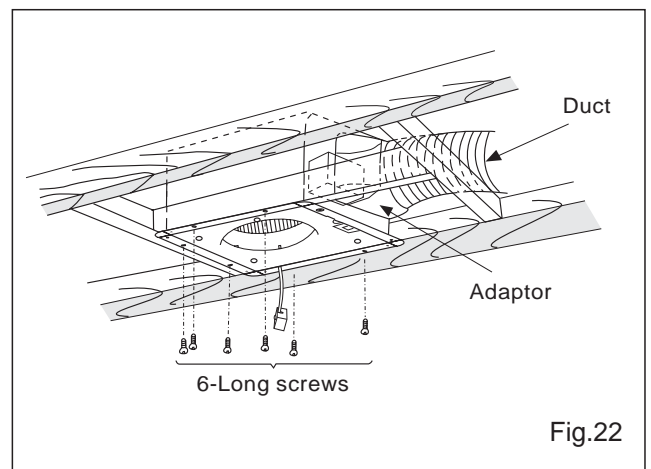
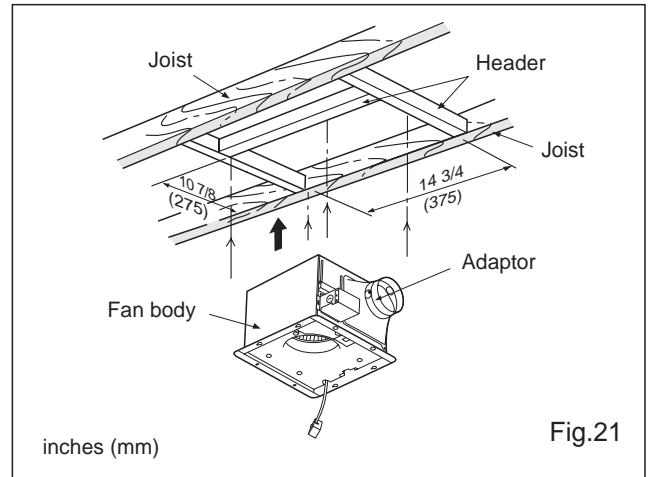

Fig.20

INSTALLATION V (WOODEN HEADER)

1. Before installation, open the orifice cover. Secure the fan body to adaptor by using thumb screw. (Fig.1 of page 8)
2. Install header between joists by using nails or screws.
3. Install the fan body and secure it by using long screws(M4X30) (Fig.21, Fig.22)
4. Connect the circular duct to the adaptor.
Remove the junction box cover and secure conduit or stress relief to junction box knockout hole. (7/8 inch) (Fig.22)
5. Follow step 5 to 10 of installation I (page 9,page 10) to complete the installation work.



INSTALLATION VI (IN EXISTING CONSTRUCTION)

1. Installation in existing construction.
Installing the fan body in an existing building requires an accessible area (attic or crawl space) above the planned installation location or existing ducting and wiring.

(1) To install the fan body, follow the procedures described in Installation II. Take the following precautions before installation.

CAUTION:

Check area above planning installation location to be sure that:

1. Duct work can be done and that area is sufficient for proper ventilation.
2. Wiring can be run to planning location.
3. No wiring or other obstructions shall interfere with installation.

- (2) Inspect duct work and wiring before proceeding with installation.
 - (3) Plan suitable location for fan body.(next to ceiling joist)
 - (4) Before installation, provide inspection and maintenance access at a location that will not interfere with installation work shown in installation II.
 - (5) First, remove ceiling section.
 - (6) Install fan body.
2. Installation from accessible area above fan location.
 - (1) Inspect duct work and wiring before proceeding with installation.
 - (2) Remove ceiling section.
 - (3) Install fan body.

MAINTENANCE

WARNING:

Disconnect power source before working on unit. Routine maintenance must be done every year.

CAUTION:

1. Never use gasoline, benzene, thinner or any other such chemicals for cleaning the ventilating fan.
2. Do not damp water to motor.
3. Do not soak resin parts in water over 60°C.

1. Remove grille pull down one mounting spring (no sensor lead passed). Remove sensor unit then pull down the other mounting spring. (Fig.23, Fig.24)

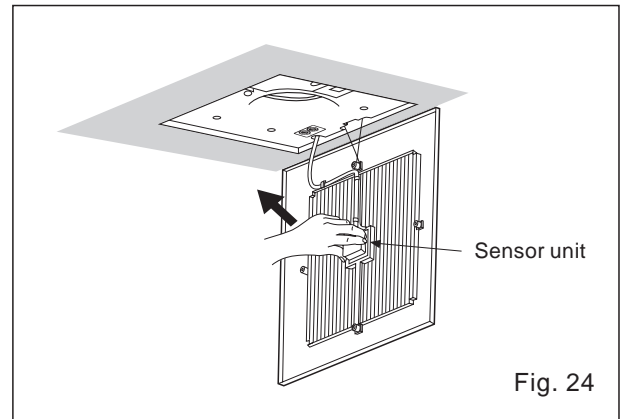
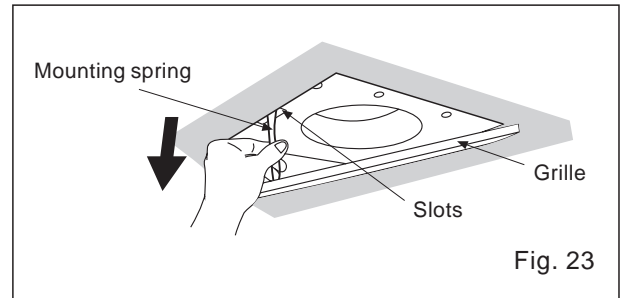

2. Wash and clean grille.(Use non-abrasive kitchen detergent, wipe dry with new cloth.) (Fig.25)

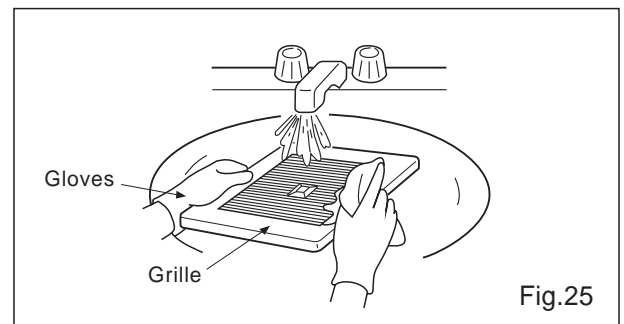

3. Remove dust and dirt from fan body using a vacuum cleaner. (Fig.26)

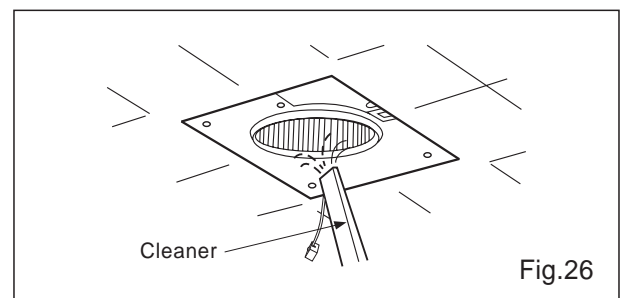

4. Using a cloth dampened with kitchen detergent, remove any dirt from fan body. Wipe dry with new cloth. (Fig.27)

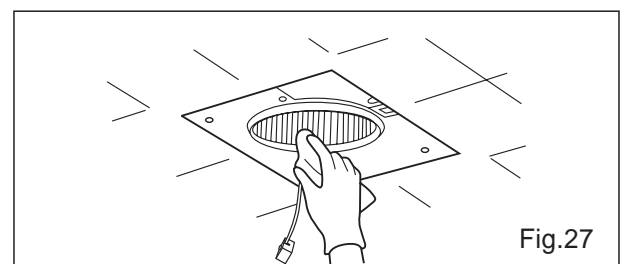

5. Replace grille.

PRACTICAL GUIDE TO INSTALLATION

Properly insulate the area around the fan to minimize building heat loss and gain. (Fig.28)

Loose fill or batt insulation can be placed directly over the fan housing in the attic. Panasonic fans and fan/light combination units do not create excessive heat that is a common problem with recessed light fixtures or some competitors' fan/light combinations. Our efficient, cool-running motors and our fluorescent lamps do not create enough ambient heat to be subjected to these limitations.

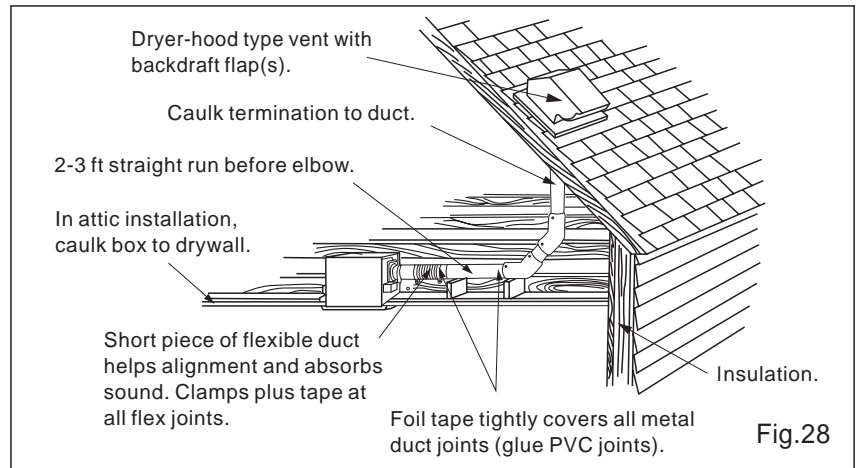

PRODUCT SERVICE

Warning Concerning Removal of Covers.

The unit should be serviced by qualified technicians only. No service information is provided for customers. Your product is designed and manufactured to ensure a minimum of maintenance. However, should your unit ever require service, a nationwide system of factory service centers and AUTHORIZED INDEPENDENT SERVICE CENTERS is maintained to support your product's warranty. (In the U.S.A., call 1-866-292-7292 to Customer call Center.)

PANASONIC CONSUMER ELECTRONICS COMPANY

One Panasonic Way, 1H-3 Secaucus, NJ 07094

PANASONIC CANADA INC.

5770 Ambler Drive, Mississauga, ON L4W 2T3